



LHD SPECIFICATIONS

The LHD is a completely hydraulic unit built to deliver maximum efficiency and power. This unit can also be mounted on a medium duty 3 axle truck and be "road legal" allowing you to get to the next job easier and faster. Crawler and short mast configurations are available as well. Add increased maintenance accessibility and features designed for greater operator ease and you have a whole new solution to your drilling needs.

TECHNICAL SPECIFICATIONS

Maximum Pile Depth	60 feet	18.28 m
Maximum Pile Diameter	72 inches	1.82 m
Maximum Torque	30,000 ft./lbs.	40.67 kNm
Maximum rpm (low)	22 rpm	22 rpm
Maximum rpm (mid)	56 rpm	56 rpm
Spin off Speed	140 rpm	140 rpm
Main Winch	12,000 lbs.	53.33 kN
Service Winch	8,000 lbs.	35.56 kN
Transport weight*	43,000 lbs.	21.5 tons
Fuel Tank	50 gallons	189 liters
Crowd	24,000 lbs.	106 kN
Engine-John Deere 4045	173 hp	

* may vary depending on configuration and undercarriage

OPTIONAL EQUIPMENT

Digital Depth and Swing Position Readout	
Short Mast Option	(25' operational height)
50' Drilling Depth option	(2 bar, 5"x7" square)
50' Drilling Depth option	(2 Bar, 4 1/2" x 7 1/4" round)
60' Drilling Depth option	(3 bar, 3 1/2" x 5" x 7" square)



LHD
Truck mounted w/ Short Mast and
35ft Square Kelly

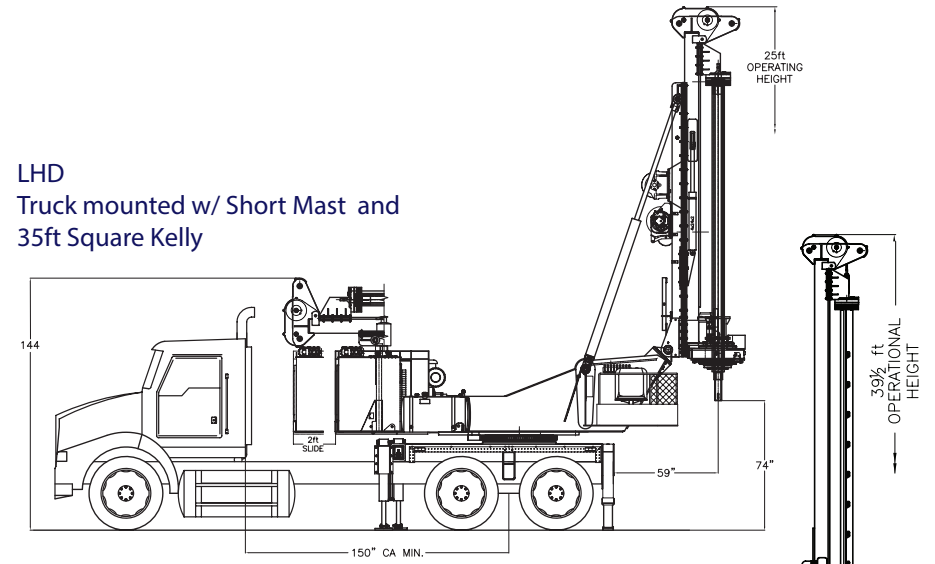

LHD
Truck mounted w/ Standard Mast and
50ft Round Kelly

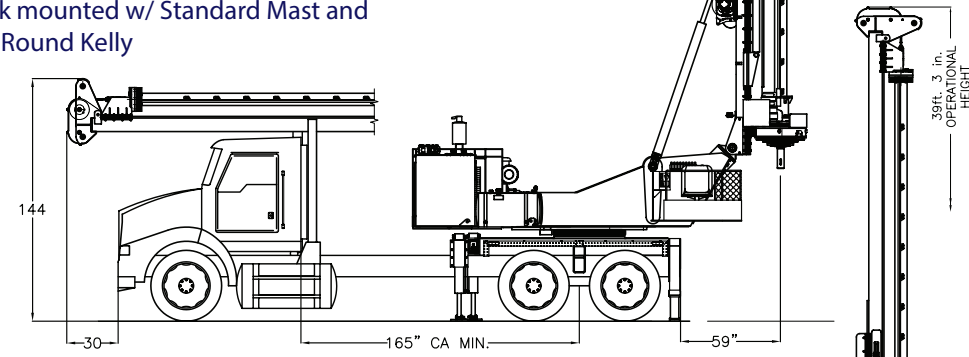

LHD
Track mounted w/ Standard Mast and
50ft Round Kelly

